



## Pyrometer Series ARDOMETER MPZ, ARDOCOL MPZ, ARDONOR MPS

Quick and exact non-contact temperature measurement from 0 °C to 3000 °C

Industrial Technologies

**SIEMENS**



# Convincing features



## General information

- Modular design
- For temperatures from 0 °C to 3000 °C
- Available either as a spectral or two-colour pyrometer

## Optics

- Focusable, interchangeable optics for correct measuring distance
- Broadband antireflection coated lenses
- Through-the-lens sighting
- Smallest target diameter 0.3 mm
- Very large field of view
- Polarisation filter provides eye protection

## Mechanical design

- Robust aluminium housing
- Rated IP 65
- Optional pressure-tight encapsulated housing permits use in explosive atmospheres
- Wide range of accessories for high protection of the pyrometer even in harsh industrial environments

## Electronics

- Digital signal processor for high accuracy
- Bright, easily readable LED display
- Protected pushbuttons for setting parameters

- Very fast response time
- Wide temperature ranges
- Based on light sensor technology; instrument contains no mechanical moving parts
- Nonwearing; requires no maintenance
- Immune to electromagnetic interference

## Interfaces

- Analogue output 0 (4) – 20 mA, linearised, switchable
- Digital interfaces RS 232, RS 422 for transmission distances up to 300 m

## PC-communication

- Integrated software for sensor configuration and data transmission
- Simple communication using Windows HyperTerminal
- Online parameter adjustment facilitates adaption to changing conditions
- CellaMevis data recording and visualisation software with graphic user interface
- Two-colour pyrometer models simultaneously transmit the temperatures at two separate wavebands as well as the ratio of these signals.

## Display/Parameter setting

- 4-digit rear panel LED display behind the cover plate has bright 8 mm high digits for excellent readability, even at greater distances.

Parameters such as emissivity, temperature range, output, smoothing constant, hold time or degree of permitted window-soiling can be set either directly at the instrument using the membrane buttons or remotely from a PC via interface.

The green READY LED (F1) indicates the current status as ready for operation. The yellow LED (F2) will light up when the instrument is in configuration mode.

## Functions

- Min/max memory
- Double maximum memory
- Smoothing
- Automatic internal temperature monitoring with alarm to prevent overheating
- Feasibility check based on user defined signal quality (for two-colour instruments)
- System function check with READY output signal
- Electronic dirty window detection (for two-colour instruments)
- Current and temperature simulation to check downstream signal processing.

# ARDOCOL - Advantages



## Spectral or two-colour pyrometers

The pyrometers of the MPZ Series are available both as spectral and as two-colour pyrometers. Whereas spectral pyrometers detect thermal radiation at one single wavelength, two-colour or ratio pyrometers pick up the infrared radiation at two different wavelength channels. The ratio of these two intensities is a function of target temperature. When the radiation detected is equally reduced at both wavelengths e.g. due to vapour or dust in the field of view, a fogged or dirty lens, or changing surface characteristics of the target, the ratio signal will remain unchanged and the two-colour instrument will continue to provide a stable measurement.

## ARDOCOL two-colour pyrometer with integrated contamination detection feature

The preconditions for correct temperature measurement are clean optics and a free line of sight for the pyrometer. A blower mounted on the front of the pyrometer helps to prevent contamination and condensation on the lens.

Thanks to the detection feature integrated in our two-color pyrometers, problems of contamination are automatically signaled to the supervising operator. The method is based on a two-color pyrometer which compares the two spectral temperatures with the calculated two-color temperature.

If the emission factors have been optimally adjusted and the line of vision between the pyrometer and the object being measured is not impaired, all three measured temperatures are the same. If the measuring signal is weakened because of some obstacle between the lens and the measuring point, the two spectral temperatures decrease but the two-color measurement continues to display the correct temperature. Even if optical transmission is weakened to a mere 10 % of the original intensity of radiation, reliable measured values are still supplied with this method.

If a critical degree of contamination is reached, a switching contact in the pyrometer triggers an alarm. The pyrometer continues to work and the supervising operator has to clean the optics and remove any obstacles in the pyrometer's "line of sight". If the contamination is excessively high, the pyrometer switches off the power output. The thresholds for the alarm and the switch-off point can be adjusted.

### Advantages:

Contamination problems are automatically signaled to the supervising operator acoustically or optically. Incorrect measurements resulting from unintentional failure to clean the optics or inspection glass cannot occur.



# Technical Data: Spectral pyrometer

Series	MPZ 10 AF...	MPZ 20 AF...		MPZ 30 AF...		MPZ 35 AF...
Measuring Range (variably adjustable)	0 °C to 1000 °C	250 °C to 2000 °C from 210 °C at $\epsilon > 0.5$	350 °C to 2500 °C from 290 °C at $\epsilon > 0.5$	500 °C to 2500 °C	800 °C to 3000 °C from 750 °C at $\epsilon > 0.5$	600 °C to 2500 °C
Interchangeable lenses						
Standard lens Pyrometer model Distance ratio	MPZ 10 AF 1 /D 40:1	MPZ 20 AF 1 /D 150:1	MPZ 20 AF 5 /D 150:1	MPZ 30 AF 1 /D 175:1	MPZ 30 AF 5 /D 175:1	MPZ 35 AF 1 /D 175:1
Order no	7MC3002-1AB10	7MC3002-1AB20	7MC3002-1AF20	7MC3002-1AB30	7MC3002-1AF30	7MC3002-1AB35
Close-up lens Pyrometer model Distance ratio	MPZ 10 AF 2 /D 38:1	MPZ 20 AF 2 /D 140:1	MPZ 20 AF 6 /D 140:1	MPZ 30 AF 2 /D 140:1	MPZ 30 AF 6 /D 140:1	MPZ 35 AF 2 /D 140:1
Order no	7MC3002-1AC10	7MC3002-1AC20	7MC3002-1AG20	7MC3002-1AC30	7MC3002-1AG30	7MC3002-1AC35
Telephoto lens Pyrometer model Distance ratio		MPZ 20 AF 3 /D 200:1	MPZ 20 AF 7 /D 200:1	MPZ 30 AF 3 /D 240:1	MPZ 30 AF 7 /D 240:1	MPZ 35 AF 3 /D 240:1
Order no		7MC3002-1AD20	7MC3002-1AH20	7MC3002-1AD30	7MC3002-1AH30	7MC3002-1AD35
Wide-angle lens Pyrometer model Distance ratio		MPZ 20 AF 4 /D 32:1	MPZ 20 AF 8 /D 32:1	MPZ 30 AF 4 /D 35:1	MPZ 30 AF 8 /D 35:1	MPZ 35 AF 4 /D 35:1
Order no		7MC3002-1AE20	7MC3002-1AJ20	7MC3002-1AE30	7MC3002-1AJ30	7MC3002-1AE35
Sensor	thermopile	photodiode				
Spectral range	8 – 14 $\mu\text{m}$	1.1 – 1.7 $\mu\text{m}$		0.8 – 1.1 $\mu\text{m}$		0.85 – 0.91 $\mu\text{m}$
Uncertainty (at $\epsilon = 1$ and $T_a = 23$ °C)	1 % of temp. reading, at least 2 K	0.75 % of temperature reading				0.5 % of temp. reading
Repeatability		1 K				
Response time $t_{90}$	$t_{90} \leq 100$ ms	$\leq 2$ ms at $T > 750$ °C		$\leq 2$ ms at $T > 1000$ °C		
Resolution	$\leq 0.5$ K	$\leq 1$ K				

## Target diagrams<sup>1)</sup>

Interchangeable optics for MPZ 10

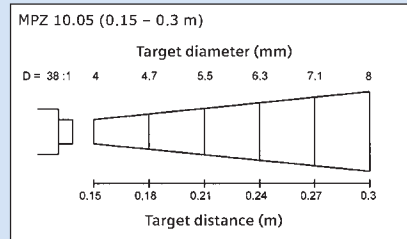
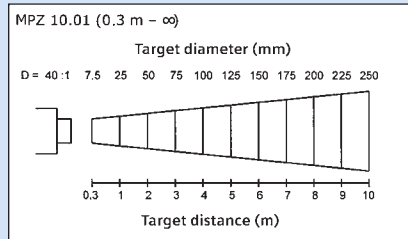

Interchangeable optics for MPZ 20, MPZ 30, MPZ35

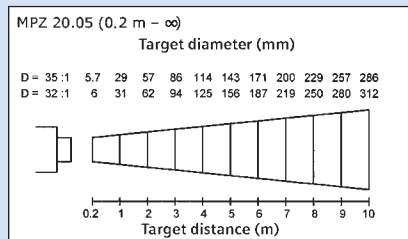
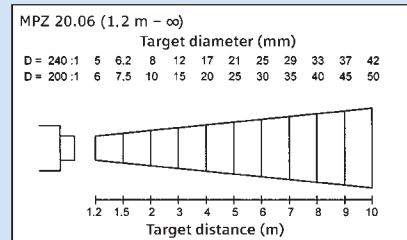
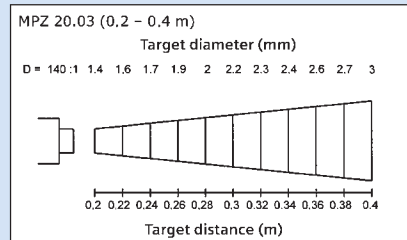
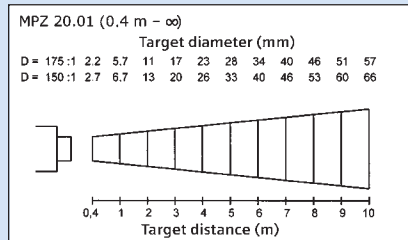

<sup>1)</sup> allowing for optical tolerance at 95 %  
(90 % for MPZ 10) of the maximum detectable energy

# Technical Data: Two-color pyrometer

Series		MPZ 40 AF...				MPZ 50 AF...	MPZ 60 AF...
Measuring Range (variably adjustable)		500 °C to 1400 °C	700 °C to 1600 °C from 650 °C at $\epsilon > 0.5$	900 °C to 2400 °C from 800 °C at $\epsilon > 0.5$	1000 °C to 3000 °C from 900 °C at $\epsilon > 0.5$	500 °C to 1400 °C from 450 °C at $\epsilon > 0.5$	385 °C to 800 °C from 300 °C at $\epsilon = 1$
Interchangeable lenses							
Standard lens	Pyrometer model Distance ratio	MPZ 40 AF 20 /D 55:1	MPZ 40 AF 1 /D 80:1	MPZ 40 AF 4 /D 150:1	MPZ 40 AF 7 /D 150:1	MPZ 50 AF 1 /D 80:1	MPZ 60 AF 1 /D 45:1
	Order no	7MC3022-1CA40	7MC3022-1AB40	7MC3022-1AE40	7MC3022-1AH40	7MC3022-1AB50	7MC3022-1AB60
Close-up lens	Pyrometer model Distance ratio		MPZ 40 AF 2 /D 75:1	MPZ 40 AF 5 /D 140:1	MPZ 40 AF 8 /D 140:1	MPZ 50 AF 2 /D 75:1	
	Order no		7MC3022-1AC40	7MC3022-1AF40	7MC3022-1AJ40	7MC3022-1AC50	
Telephoto lens	Pyrometer model Distance ratio		MPZ 40 AF 3 /D 120:1	MPZ 40 AF 6 /D 240:1	MPZ 40 AF 9 /D 240:1	MPZ 50 AF 3 /D 120:1	
	Order no		7MC3022-1AD40	7MC3022-1AG40	7MC3022-1AK40	7MC3022-1AD50	
Wide-angle lens	Pyrometer model Distance ratio		MPZ 40 AF 10 /D 17:1	MPZ 40 AF 11 /D 35:1	MPZ 40 AF 12 /D 35:1	MPZ 50 AF 4 /D 15:1	
	Order no		7MC3022-1BA40	7MC3022-1BB40	7MC3022-1BC40	7MC3022-1AE50	
Sensor	Double photodiode						
Spectral range	0.95 / 1.05 $\mu\text{m}$					0.95 / 1.55 $\mu\text{m}$	1.5 / 1.95 $\mu\text{m}$
Uncertainty (at $\epsilon = 1$ and $T_a = 23\text{ °C}$ )	1 % of temperature reading						
Repeatability	2 K						
Response time $t_{99}$	$\leq 10\text{ ms}$ at $T > 600\text{ °C}$	$\leq 10\text{ ms}$ at $T > 750\text{ °C}$	$\leq 10\text{ ms}$ at $T > 950\text{ °C}$	$\leq 10\text{ ms}$ at $T > 1050\text{ °C}$	$\leq 16\text{ ms}$ at $T > 600\text{ °C}$	$\leq 100\text{ ms}$ at $T > 350\text{ °C}$	
Resolution	$\leq 1.5\text{ K}$						$\leq 1.0\text{ K}$

## Target diagrams<sup>1)</sup>

Interchangeable optics for MPZ 40, MPZ 50

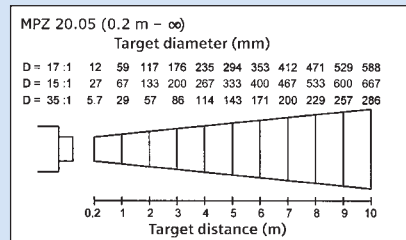
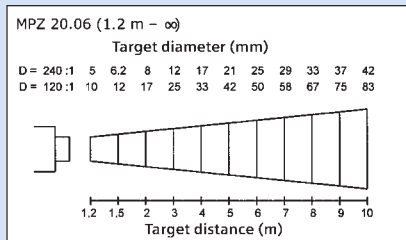
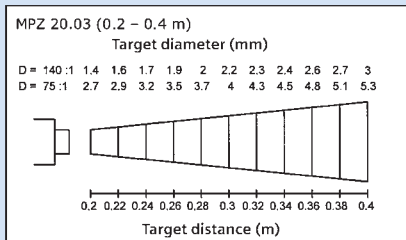
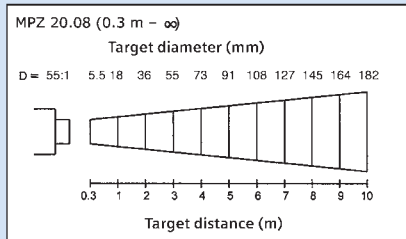
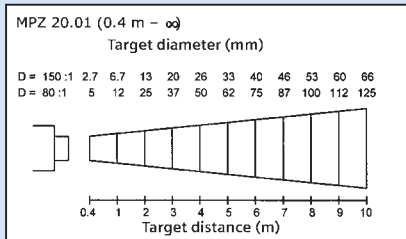

<sup>1)</sup> allowing for optical tolerance at 95 %  
of the maximum detectable energy

# Technical Data: Pyrometer for special applications

Series		for glass surfaces MPZ 15 AF...	for laser heat treatment MPZ 27 AF...		
Measuring Range (variably adjustable)		1000 °C to 2500 °C	150 °C to 800 °C from 100 °C at $\epsilon = 1$	180 °C to 1200 °C from 150 °C at $\epsilon > 0.5$	250 °C to 2000 °C from 200 °C at $\epsilon > 0.5$
Interchangeable lenses					
Standard lens	Pyrometer model Distance ratio	MPZ 15 AF 1 /D 55:1	MPZ 27 AF 10 /D 40:1	MPZ 27 AF 21 /D 60:1	MPZ 27 AF 1 /D 150:1
Order no		7MC3002-1AB15	7MC3002-1BA27	7MC3002-1CB27	7MC3002-1AB27
Close-up lens	Pyrometer model Distance ratio				MPZ 27 AF 2 /D 140:1
Order no					7MC3002-1AC27
Telephoto lens	Pyrometer model Distance ratio			MPZ 27 AF 23 /D 96:1	MPZ 27 AF 3 /D 200:1
Order no				7MC3002-1CD27	7MC3002-1AD27
Wide-angle lens	Pyrometer model Distance ratio				
Order no					
Sensor		thermopile		photodiode	
Spectral range		4.46 – 4.82 $\mu\text{m}$		1.8 – 2.2 $\mu\text{m}$	
Uncertainty (at $\epsilon = 1$ and $T_A = 23\text{ °C}$ )		1 % of temperature reading, at least 2 K		0.75 % of temperature reading, at least 5 K	
Repeatability		3 K		2 K	
Response time $t_{99}$		$t_{99} \leq 100\text{ ms}$		$\leq 2\text{ ms}$ at $T > 250\text{ °C}$	
Resolution		$\leq 1.5\text{ K}$		$\leq 1\text{ K}$	

## Target diagrams<sup>1)</sup>

Interchangeable optics for MPZ 15

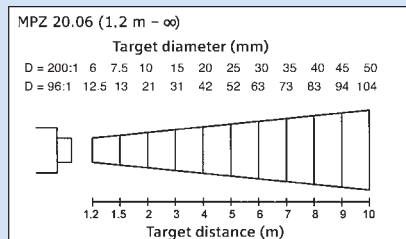
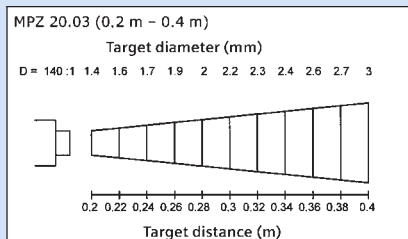
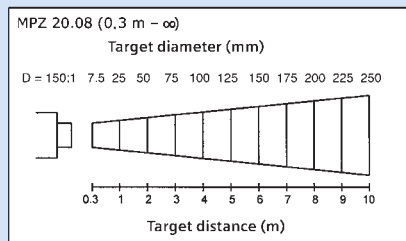
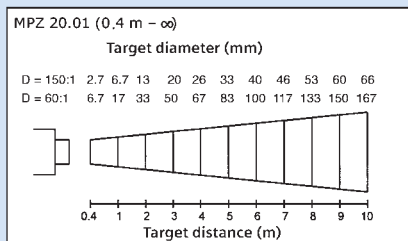
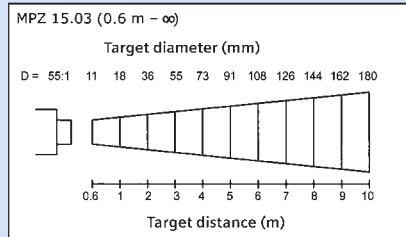
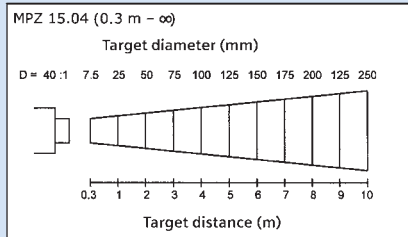

<sup>1)</sup> allowing for optical tolerance at 95 %  
(90 % for MPZ 15, MPZ 27 AF 10) of the  
maximum detectable energy

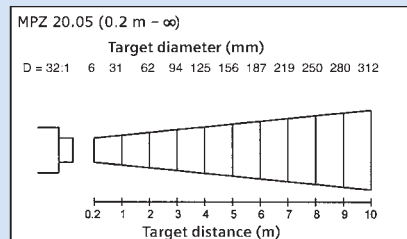

# Common Specifications

Analogue output	0 (4) up to 20 mA linear, switchable
Load	max. 500 Ohm
Serial communications	Point-to-point connection RS 232 or RS 422 with integrated communications software for remote configuration, monitoring and data acquisition
Emissivity	10 to 100 %; increments of 1 % (0.1 % at MPZ 10, MPZ 15)
Emissivity slope	74.4 to 125.5; increments of 0.1
Smoothing function	0 up to 16 s
Signal processing options	Min/max memory, double peak memory with adjustable hold time
Linearisation	Digital via microcontroller
Temperature coefficient (deviation to 23 °C)	0.25 K/K (at T < 500 °C) (0.1 K/K at MPZ 10, MPZ 15) 0.05 %/K (at T ≥ 500 °C)
Electromagnetic compatibility	according to EN 50081-1; EN 50081-2, EN 50082-1, EN 50082-2
Power supply	22 to 27 V <sub>DC</sub> / < 60 mA
Storage temperature	-20 °C to 70 °C
Ambient temperature	0 °C to 60 °C
Housing material	Aluminium
Weight	approx. 1.2 kg
Protection rating	IP 65
Optional accessories	Calibration certificate according to ISO 9001; Calibration certificate according to DKD; Large variety of accessories (protection, digital displays etc.); PC measuring and visualisation software CellaMevis

## Dimensions:

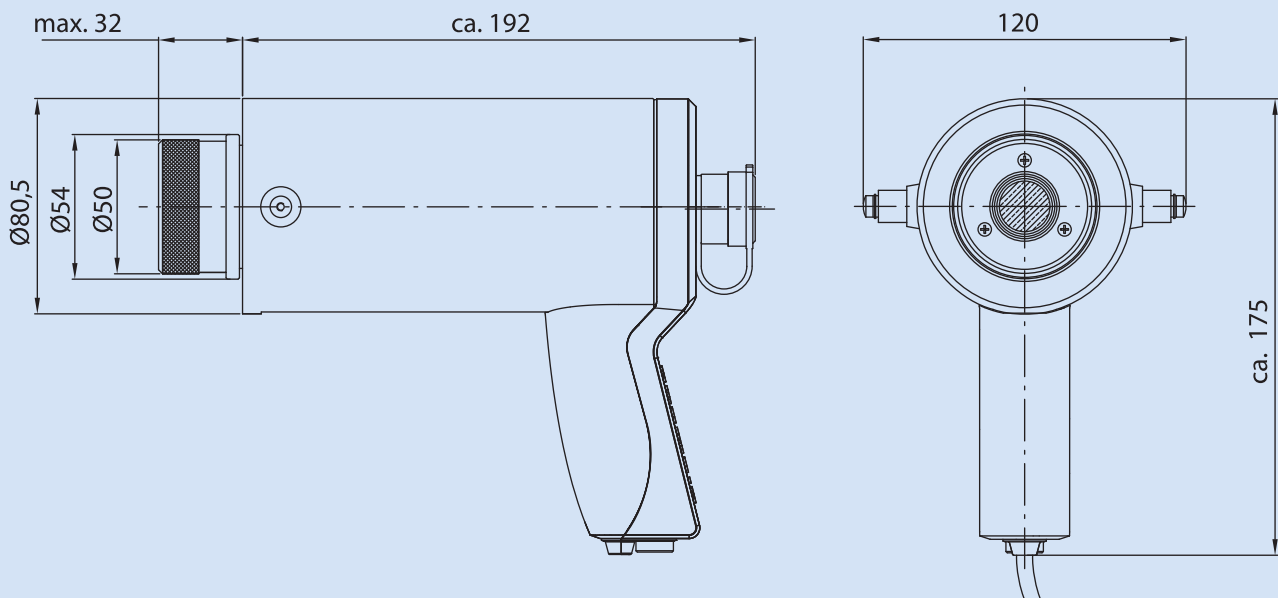

# Accessories program for ARDOMETER, ARDOCOL, ARDONOR



M264-A2

The accessories of the MPZ series can be individually adapted to the measuring location. The modular design enables the individual components to be combined to match the particular application in question.

## M264-A2

Built-in accessory, consisting of

- a connecting head with quick-release fastener (C71450-A0180-A002) and
- a sighting tube (C71450-A0180-A012) made of steel which allows it to be welded in place (for thick furnace walls; can be used at temperatures up to +550 °C).

## M264-A4

Built-in accessory, same as described under M264-A2 but also featuring a cooling clamp (C71450-A0180-A017).

## M264-A6

Built-in accessory with cooling jacket, consisting of

- a quick release fastener (C71450-A0180-A002) and
- a sighting tube with cooling jacket (C71450-A0180-A016).

## M264-A10

Connecting head with flange, consisting of a connecting head with

- a quick-release fastener (C71450-A0180-A002) and
- a connecting flange (C71450-A0180-A003).

## M264-A12

Built-in accessory for pit furnaces, consisting of

- a connecting head with quick-release fastener (C71450-A0180-A002),
- a 215 mm long flange tube (C71450-A0180-A008),
- a flange with tube (C71450-A0180-B010),
- a set of mounting components (C71450-A0180-D002) and
- a set of seals (C71450-A0180-D003).

The ceramic extension tube for temperatures up to 1550 °C must be ordered separately.



M264-A4



M264-A6



M264-A10



M264-A12





**M264-A14**



**M264-A16**



**M264-A20**



**M264-A30**

### **M264-A14**

Top-mounted accessory for feeders, consisting of

- a connecting head with quick-release fastener (C71450-A0180-A002),
- a flange tube with unions for scavenging air used to keep the pyrometer's optics clean (C71450-A0180-A005),
- a mounting flange (C71450-A0180-A011) for fastening the ceramic extension tube or sighting tube,
- a disc (C71450-A0180-C023),
- a clamping ring (C71450-A0180-C048) and
- a set of seals (C71450-A0180-D004).

The ceramic sighting tube for temperatures up to 1200 °C acts as a shield against flame and gas radiation and is to be ordered separately.

### **M264-A16**

Top-mounted accessory for blast heating apparatus or for furnaces under a pressure up to 6 bar, consisting of

- a connecting head with quick-release fastener (C71450-A0180-A002) and
- a flange tube with quartz disc (C71450-A0180-A010).

### **M264-A20**

Stand for terminal socket and adjusting tube, consisting of

- a connecting head with quick-release fastener (C71450-A0180-A002),
- an intermediate tube (C71450-A0180-A007),
- a stand (C71450-A0180-A013) and
- a clamping support with adjusting tube (C71450-A0180-A015).

### **M264-A30**

Connecting head with ball flange (can be swiveled up to 5 °) for very precision adjustment of the pyrometer to small measuring objects, consisting of

- a connecting head with quick-release fastener (C71450-A0180-A002),
- a 115 mm long intermediate tube (C71450-A0180-A007) and
- a ball flange (C71450-A0180-A004).

**Additional accessories for other applications available on request.**

# Infrared Temperature Switch

## ARDONOR MPS 122



### ARDONOR MPS 122

Fast, precise and contact-free temperature limit switches for the temperature range 300 °C up to 1300 °C

#### Technical Data (Order No 7MC3051-8AA)

Setting range	300 °C to 1300 °C (Switching point 10 K)
Sensor	InGaAs-photo diode
Spectral range	1.1 – 1.7 μm
Focussing distance	300 mm
Distance ratio	30:1
Switching output	low: ≤ 1.5 V high: > U <sub>b</sub> -4.5V I <sub>out</sub> max: ≥ +50 mA
Response time of switch	(R <sub>i</sub> = 470 Ohm; C <sub>i</sub> ≤ 100 pF) Rise time: t <sub>r</sub> ≤ 4 μs typ. Fall time: t <sub>f</sub> = 2.5 μs typ. Delay time: t <sub>d</sub> ≤ 10 ms at T <sub>o</sub> = 300 °C to 500 °C t <sub>d</sub> ≤ 2 ms at T <sub>o</sub> = 500 °C to 1300 °C
Accuracy of switching point	± 10 K (at T <sub>a</sub> = 23 °C and ε = 1)
Repeatability	± 5 K
Hysteresis	approx. 10 K
Temperature coefficient	± 0.05 % of reading/K deviation from T <sub>a</sub> = 23 °C in the range of 10 °C to 60 °C
Power supply	24 V <sub>DC</sub> +10 % / -20 % ≤ 25 mA + I <sub>out</sub>
Max. air humidity	95 % r. H. (not condensing)
Ambient temperature	0 °C to 65 °C (without cooling device)
Housing material	Aluminium
Weight	approx. 1 kg
Protection class	IP 65 according to DIN 40050
Adjustable parameters	Switching point <ul style="list-style-type: none"> <li>■ external via cable (8 bit binary signal)</li> <li>■ Setting range 300 °C to 1300 °C</li> <li>■ Increment steps 10 K</li> <li style="padding-left: 20px;">Inverting of switch contact</li> <li>■ external via cable (1 control bit)</li> </ul>

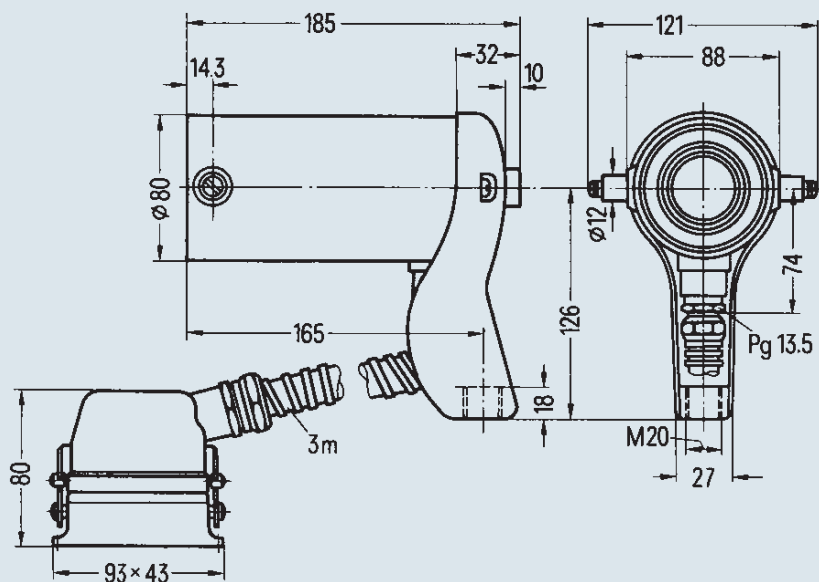

#### Target diagram 7MC3051-8AA

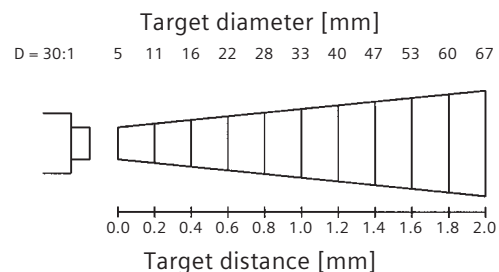

# Application Examples



## Measurement of the molten metal pouring stream

The CellaCast system consists of a two-colour pyrometer and a digital display programmed to automatically record the temperature per casting.

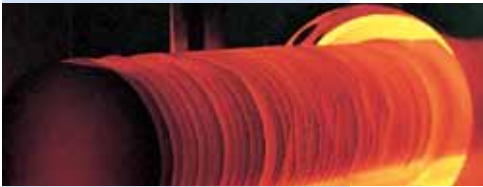

## Crystal growing facilities

ARDOMETER MPZ and ARDOCOL MPZ pyrometers meet the demands of the semiconductor and glass crystal industries which require extremely precise and stable measurements over long periods.



## Combustion plants, coking plants

Because of the extreme measuring conditions, two-colour pyrometers are used in combustion plants or coking plants.



## Induction hardening

### Automatic laser welding

Quick and safe temperature detection of even very small objects in places with limited space.



## Within blast furnaces; forging, hardening and tempering

The temperature has a considerable influence on the manufacturing, treatment and subsequent treatment process in many areas of the metal industry.



## Rolling mills, galvanizing plants

Quick and exact temperature detection is a prerequisite for steady quality during the rolling of billets and slabs and for the coating of metal strips.



## Glass industry

Temperature measurement in the glass tank, of glass gobs, at the arch, at glass moulds or in the cooling zone.



## Rotary kiln

Measurement of the clinker temperature at the kiln entrance and exit; monitoring shell temperature to check for refractory damage.

## Annealing kiln

Nonwearing measuring system for the direct and quick detection of the object temperature guarantees optimum kiln control.

## More information

Siemens Aktiengesellschaft  
Industry Sector  
Industry Solutions Division  
Industrial Technologies  
I IS IN OC RL ITM  
Günther-Scharowsky-Straße 2  
91058 Erlangen  
phone: 09131 / 73 33 10  
E-Mail: sirent.industry@siemens.com

The information in this document contains general descriptions of the technical options available, which do not always have to be present in individual cases. The required features should therefore be specified in each individual case at the time of closing the contract.

All designations used in this document can be trademarks the use of which by third parties for their own purposes could violate the rights of their owners.

Order-No.: E10001-T430-A71-V1-7600  
Printed in Germany  
Dispo No. 21639 K-No. 38300  
NOR C-ISOL5208M0702 WS 06101.  
Subject to change without prior notice

© Siemens AG 2010.  
All Rights Reserved.